

EDGE^M TMS

Transcranial Magnetic Stimulation Chair



 EDGE SURGICAL SOLUTIONS

Registered Community Design

WHO WE ARE | QUI NOUS SOMMES | CHI SIAMO

THE COMPANY

EDGE SURGICAL SOLUTIONS is specialized in developing and manufacturing Multispecialty Examination and Surgery Chairs, Surgeon's Stools and Furniture.

EDGE SURGICAL SOLUTIONS is committed to the continuous research of innovative technical solutions for the Professionals; the range of equipment offered is based on and follows rigid guidelines: latest technology, perfect work-flow ergonomics, reliability, design and highly intuitive and easy to operate by the Professional.

The Company is directly involved through all development, manufacturing, assembly and quality control, shipment, installation and after-sale service phases thanks to its vast network of Distributors and Agents.

In the Company premises there is a permanent Show-Room and a Training Area for theory-practice sessions.

A well structured company organization that has enabled EDGE SURGICAL SOLUTIONS to grow at national and international level keeping the highest quality standards and constant innovation of its range of products.

ENTREPRISE

EDGE SURGICAL SOLUTIONS est spécialisée dans la conception et la fabrication de Fauteuils Polivalents et pour la Chirurgie Ambulatoire, Siège Praticien et Meubles.

EDGE SURGICAL SOLUTIONS est engagée dans la recherche constante de solutions innovantes pour les opérateurs professionnels; la gamme qu'elle propose suit des directives très précises: ergonomie, fiabilité, design et une simple utilisation pour les opérateurs.

La Société est directement impliquée dans chaque phases de conception et de développement de ses produits, à partir de la production et l'assemblage, au contrôle, jusqu'à l'expédition et la distribution, offrant un support technique et commercial complet et compétent. Tout cela grâce à un réseau coordonné et capillaire reliant ses agents et ses partenaires-distributeurs et grâce à son service après-vente interne.

A l'intérieur de son établissement, EDGE SURGICAL SOLUTIONS propose une salle d'exposition permanente et une salle de formation pour l'entraînement théorique et pratique.

Une organisation qui nous a permis de nous développer au bout des années sur le marché Nationale et Internationale, toujours en gardant les plus hauts standards de qualité et un renouvellement constant de notre gamme de produits.



“All EDGE SURGICAL SOLUTIONS Medical Equipment is designed, developed and manufactured in Italy”

L'AZIENDA

EDGE SURGICAL SOLUTIONS è specializzata nella progettazione e nella fabbricazione di Poltrone Chirurgiche Multispecialistiche, Seggiolini Chirurgici e Arredi.

EDGE SURGICAL SOLUTIONS è impegnata nella continua ricerca di soluzioni innovative per gli Operatori professionali; la gamma che propone si basa su linee guida molto rigide: ergonomia, affidabilità, design e massima semplicità di utilizzo per gli Operatori.

L'Azienda è direttamente coinvolta in tutte le fasi di progettazione e sviluppo, produzione e assemblaggio, controllo, spedizione e commercializzazione, offrendo un supporto tecnico e commerciale completo e competente grazie ad una rete capillare di Agenti e Distributori ed un Servizio Assistenza Interno.

Nella sua sede EDGE SURGICAL SOLUTIONS offre uno Show-room permanente ed una Sala Corsi per la Formazione.

Una organizzazione aziendale che ci ha permesso in pochi anni di crescere a livello nazionale ed internazionale mantenendo i più alti standard qualitativi e il rinnovamento costante della gamma prodotti.



HOW WE WORK | COMMENT NOUS TRAVAILLONS | COME LAVORIAMO

R&D

EDGE SURGICAL SOLUTIONS R&D Team develops internally all the equipment and devices for the Professionals and Clinics, always combining modern and essential design to the latest and most innovative technical solutions.

L'équipe EDGE SURGICAL SOLUTIONS Design développe en interne tout équipements dédiés au Professionnel et à la Cabinet, toujours en alliant un design moderne avec les solutions techniques les plus fonctionnelles et innovantes.

Il Team di Progettisti EDGE SURGICAL SOLUTIONS sviluppa internamente tutte le attrezzature dedicate al Professionista e alla Clinica, coniugando sempre con attenzione un design moderno alle soluzioni tecniche e funzionali più innovative.



R&D
R&D
R&D



EDGE SURGICAL SOLUTIONS manufactures a wide and complete range of Surgical Chairs, Doctor Stools and Furniture. Every single production phase is planned and performed according to the most rigid quality control criteria.

EDGE SURGICAL SOLUTIONS réalise sa gamme complète de Fauteuils de Chirurgie, Sièges Praticien et Meubles. Chaque phase de la production est organisée suivant des critères très stricts de qualité et de contrôle.

EDGE SURGICAL SOLUTIONS produce una gamma completa di Poltrone Chirurgiche, Sgabelli e Arredi. Ogni fase produttiva è organizzata secondo rigidi criteri di qualità e controllo.



PRODUCTION
PRODUCTION
REALIZZAZIONE

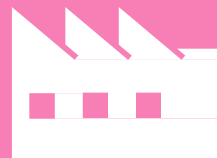

EDGE SURGICAL SOLUTIONS will design your Ambulatory Surgery Center in order to allow for the best work-flow and ergonomics while guaranteeing maximum comfort to the Patient, according to the space availability and your different set up needs as a Professional.

Nous étudions les meilleures solutions de projet pour votre Salle de Chirurgie Ambulatoire, afin de vous garantir une parfaite ergonomie et un maximum de confort, tout en gardant toujours les solutions les plus adaptées à votre espace.

Progettiamo il tuo Ambulatorio Chirurgico per garantirti la migliore ergonomia di lavoro e il massimo comfort proponendo sempre le soluzioni più adeguate al tuo spazio.



PROJECT
PROJET
PROGETTO

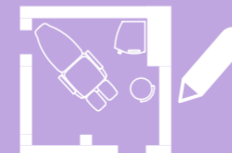

INSTALL
INSTALL
INSTALL



All EDGE SURGICAL SOLUTIONS equipment is "Plug-in & Work" easy to set up and ready to use with very few and easy installation steps. EDGE SURGICAL SOLUTIONS guarantees a highly professional installation service thanks to its vast network of Distributors and Agents, and a product specialist will train the Ambulatory staff on the correct use of the installed equipment.

Tous les équipements EDGE SURGICAL SOLUTIONS sont fabriqués suivant le principe du "Plug-in & Work", facile à installer et avec un service d'expédition et de livraison consolidés. EDGE SURGICAL SOLUTIONS garantit un service professionnel d'installation de votre Cabinet grâce à un réseau de distributeurs impliqués dans chaque phase. Un de nos technico-commerciaux vous garantira une formation complète pour l'utilisation de tout équipements à l'intérieur de votre Cabinet.

Tutte le Attrezzature EDGE SURGICAL SOLUTIONS sono realizzate con il principio del "Plug-in & Work", facili da installare e con un servizio di spedizione e consegna dedicato. EDGE SURGICAL SOLUTIONS garantisce un servizio professionale di allestimento del tuo Ambulatorio grazie ad una vasta rete di Distributori che ne seguono ogni fase. Un nostro product specialist garantirà la formazione in loco sull'utilizzo delle attrezzature installate nel tuo Ambulatorio.



EDGE SURGICAL SOLUTIONS is committed to continuous training and information of all its Customers; the Company can rely on the cooperation with prominent experts in each medical discipline and often involved in training sessions on the specific equipment and different operating methods.

EDGE SURGICAL SOLUTIONS connaît l'importance de promouvoir de l'information et de la formation de tous ses clients, en collaboration avec des experts du secteur et en organisant des sessions de formations dédiées aux équipements et à techniques très spécifiques.

EDGE SURGICAL SOLUTIONS promuove da sempre l'informazione e la formazione dei suoi clienti collaborando con prominenti esperti di settore e organizzando sessioni e corsi di formazione dedicati alle varie e specifiche attrezzature e metodiche operative.



EDGE SURGICAL SOLUTIONS considers Warranty a professional duty and mandatory towards all its Customers, reason being the Company extends guarantee of the equipment up to 2 Years on Electronic Parts and up to 5 Years on Mechanic Parts.

EDGE SURGICAL SOLUTIONS considère la garantie des produits comme un engagement ferme envers tous ses clients. Pour cette raison, la garantie de nos équipements couvre jusqu'à 2 ans pour les composants électroniques et jusqu'à 5 ans tout composants mécaniques.

EDGE SURGICAL SOLUTIONS considera la Garanzia dei prodotti un dovere verso tutti i suoi clienti e per questo garantiamo le nostre attrezzature fino a 2 anni per le componenti elettroniche e fino a 5 anni per tutte le componenti meccaniche.

All Customers can rely on a punctual and qualified after-sale assistance thanks to the in-house Service Department. You will be able to request a Preventive Maintenance and Courtesy Service to our Distributors and avoid any unexpected interruption of your professional activity.

Nos clients peuvent compter sur un SAV rapide et qualifié, grâce à son Département interne. Vous aurez également la possibilité de profiter d'un service de maintenance programmé, ainsi que d'un "Service de Courtoisie" assuré par nos Distributeurs afin d'éviter toute interruption de votre activité professionnelle.

I nostri clienti possono contare su un Servizio di Assistenza puntuale e qualificato grazie al dipartimento Service interno. Avrai la possibilità di richiedere un Servizio di Assistenza Programmata e il Servizio "Cortesia" al Distributore incaricato per non avere mai interruzioni della tua attività professionale.



INSTALLATION
INSTALLAZIONE



TRAINING
FORMATION
FORMAZIONE



WARRANTY
GARANTIE
GARANZIA



SERVICE
SERVICE APRES-VENTE
ASSISTENZA



EDGE^M TMS

Transcranial Magnetic Stimulation Chair



EDGE^M TMS

A transformative and state of the art model for modern TMS (Transcranial Magnetic Stimulation) Therapy.

It is EDGE SURGICAL SOLUTIONS ultimate concept Specialty Treatment Chair developed and manufactured exclusively for the most modern and efficient TMS Therapy both Clinical and Research.

Il est le concept ultime et innovant de EDGE SURGICAL SOLUTIONS de Fauteuil développé et fabriqué exclusivement pour le traitement spécialisé et la thérapie TMS (Stimulation Magnétique Transcrânienne) les plus modernes et efficaces, destinées à la fois pour toute activité en Clinique et de Recherche.

E' il modello innovativo e all'avanguardia per la moderna terapia TMS (Stimolazione magnetica Transcranica).

è la poltrona per trattamenti speciali di EDGE SURGICAL SOLUTIONS di ultima generazione sviluppata e prodotta esclusivamente per la più moderna ed efficiente terapia TMS sia clinica che di ricerca.

Registered Community Design

EDGE^M TMS

Thanks to an innovative engineering and the highest constructive approach **EDGE^MTMS** sets new and higher standards in the industry; the Memory Foam and independent padded sections are electrically adjusted guaranteeing the correct positioning and the best comfort for the patient during the treatment session, while the Foot Control and the Articulated Headrest allow for perfect positioning of the area during the procedure.

The unique design of **EDGE SURGICAL SOLUTIONS** Articulated Headrest grants extreme versatility and precision, the side bars are adjustable (up/down and left/right) and removable, padded for better comfort and manufactured in Aluminium (including the screws) with a marking hole in the terminal block (available version without marking block). The back bar allows for perfect head stability and it allows for up/down and forward/backward adjustment thanks to an innovative articulation.

All surfaces are easy to disinfect and the quality of all materials is guaranteed for 2 (Electronic parts) and 5 (Mechanical parts) years.

EDGE^M TMS is paramount in Clinical and Research activity in the modern Neurostimulation and Therapy Centres.

*Grâce à son ingénierie innovante et son concept de fabrication de niveau le plus élevé, **EDGE^MTMS** établit de nouveaux niveaux de qualité dans son domaine; la mousse à mémoire de forme et les sections rembourrées indépendantes sont gérées électriquement, tout en garantissant le positionnement correct et le meilleur confort pour le Patient lors du traitement, tandis que la pédale de commande et l'appui-tête articulé permettent une parfaite ergonomie.*

L'appui-tête articulé est unique dans sa conception, offrant une polyvalence et une précision extrêmes, les barres latérales sont amovibles et réglables (vers le haut/bas et gauche/droite) ainsi que rembourrées pour un confort maximal. Fabriquées en aluminium (y compris les vis) avec un point de repère au bout (version disponible sans point de repère). La barre arrière permet une parfaite stabilité de la tête ainsi que le réglage vers le haut/bas et avant/arrière grâce à un système d'articulation innovant.

L'ensemble des surfaces sont facilement désinfectables tandis que la qualité des matériaux est garantie 2 ans (pièces électroniques) et 5 ans (structures mécaniques).

EDGE^M TMS est primordial pour toute activité en Clinique et de Recherche au sein de Centres modernes de Neurostimulation et Thérapie. **EDGE^M TMS** è fondamentale nell'attività clinica e di ricerca nei moderni Centri di Neurostimolazione e Terapia.

Grazie a un progetto innovativo e al più alto approccio costruttivo, **EDGE^MTMS** stabilisce nuovi ed elevati standard nel settore; il Memory Foam e le sezioni imbottite indipendenti sono regolate elettricamente garantendo il corretto posizionamento e il miglior comfort per il paziente durante la seduta di trattamento, mentre il comando a pedale e il poggiatesta articolato consentono un perfetto posizionamento dell'area durante la procedura.

Il design unico del poggiatesta articolato **EDGE SURGICAL SOLUTIONS** garantisce estrema versatilità e precisione, le barre laterali sono regolabili (su/giù e sinistra/destra) e rimovibili, imbottite per un miglior comfort e realizzate in alluminio (comprese le viti) con foro di marcatura nel blocco terminale (disponibile versione senza blocco di marcatura). La barra posteriore permette una perfetta stabilità della testa e permette la regolazione su/giù e avanti/indietro grazie a un'innovativa articolazione.

Tutte le superfici sono facilmente disinfettabili e la qualità di tutti i materiali è garantita per 2 (parti elettroniche) e 5 (parti meccaniche) anni.

EDGE^M TMS è fondamentale nell'attività clinica e di ricerca nei moderni Centri di Neurostimolazione e Terapia.



Registered Community Design



plug & work



wireless



memory



zero position



disinfection



4motors



80 colours available

Registered Community Design



plug & work



wireless



memory



zero position



disinfection



4motors



80 colours available

Registered Community Design

code	description
9110524-W	EDGE M TMS (white structure)
9110524-S	EDGE M TMS (silver structure)

code	description
9110519-W	Mobile EDGE M TMS (white structure)
9110519-S	Mobile EDGE M TMS (silver structure)

EDGE M TMS



EDGE M TMS chair reaches a minimum height of 48 cm allowing patients with different medical conditions to easily access the chair from the front or the sides without any barrier.

EDGE M TMS atteint une hauteur minimum de 48 cm permettant aux patients souffrant de différentes conditions d'accéder facilement au fauteuil par l'avant ou des côtés, sans aucune barrière.

EDGE M TMS raggiunge un'altezza minima di 48 cm consentendo ai pazienti di accedere facilmente dalla parte anteriore o laterale, senza nessuna barriera.



EDGE M TMS can automatically reach the Operating Position thanks to the memorable positions function activated by the foot control.

EDGE M TMS peut atteindre automatiquement la Positionnement Opérateur grâce aux touches mémoire de la pédale de commande.

EDGE M TMS può raggiungere in maniera automatica la Posizione Operatoria grazie all'utilizzo dei tasti memoria del pedale di comando.



EDGE M TMS is equipped with medical grade castors, two of them are pivoting while 2 fixed, and central brake system at rear, in order to provide maximum maneuverability.

EDGE M TMS est équipé de roulettes de qualité médicale, 2 pivotantes et 2 fixes pour une maniabilité aisée, équipées d'un système de blocage centralisé.

EDGE M TMS è dotata di ruote di tipo medico, 2 girevoli e 2 fisse per una facile manovrabilità, dotate di sistema di chiusura centralizzata.



EDGE M TMS chair can reach a perfect flat position at any height, for the maximum comfort of the Operator while performing a clinical examination or professional procedure. Maximum height 88 cm.

Le fauteuil **EDGE M TMS** peut atteindre une position parfaitement plate à n'importe quelle hauteur, pour le maximum de confort pour l'opérateur lors d'un examen ou un traitement professionnel. Hauteur maximum 88 cm.

88 cm **EDGE M TMS** raggiunge la posizione lettino a qualsiasi altezza, per il massimo comfort dell'operatore durante l'esecuzione di un esame clinico o un trattamento professionale. Altezza massima 88 cm.

93 cm (Mobile Edge M TMS)



Zero position of the chair.

EDGE^M TMS chair automatically reaches "0" position to facilitate the access and the exit of the Patient.

Remise à zéro du fauteuil. Le fauteuil EDGE^M TMS atteint la position "0" automatiquement pour faciliter l'accès et la descente du Patient.

Ritorno a zero. EDGE^M TMS raggiunge automaticamente la posizione "0" per facilitare l'accesso e l'uscita del paziente.



EDGE^M TMS allows the operator to perform "Synchro" movements of the Chair enables the combined and synchronized movement of the back-rest and leg-rest.

EDGE^M TMS permet à l'Opérateur des mouvements synchronisé du dossier et jambière. par la fonction "Synchro" du Fauteuil.

EDGE^M TMS consente all'operatore di eseguire movimenti "Synchro" della Poltrona, ovvero il movimento combinato e sincronizzato dello schienale e del gambale.



EDGE^M TMS can rely on a lifting capacity of 325 kg, one of the highest in its category.

EDGE^M TMS est en mesure d'atteindre une capacité de levage de 325 kg, l'une des plus élevée de sa catégorie.

EDGE^M TMS è in grado di assicurare una capacità di sollevamento di 325 kg, uno dei più alti nella sua categoria.

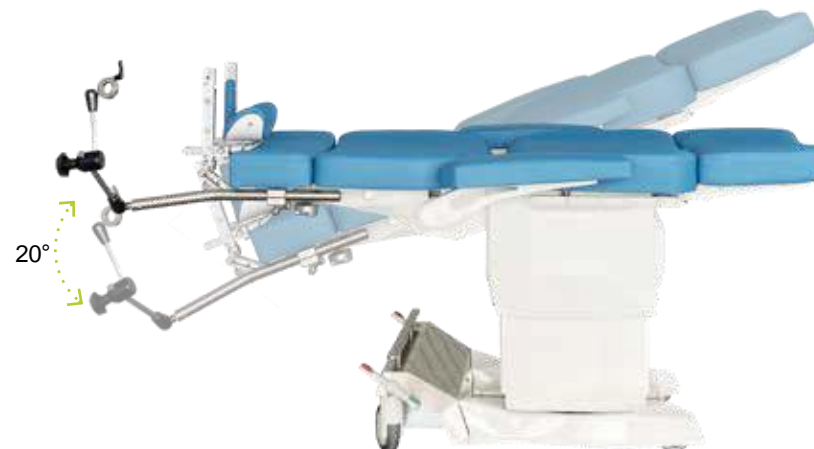

EDGE^M TMS reaches Trendelenburg position with 20° inclination.

EDGE^M TMS atteint la position Trendelenburg avec une inclinaison de 20°.

EDGE^M TMS raggiunge la posizione di Trendelenburg con un'inclinazione di 20°.



The unique design of EDGE SURGICAL SOLUTIONS Articulated Headrest grants extreme versatility and precision, the side bars are adjustable (up/down and left/right) and removable, padded for better comfort and manufactured in Aluminium (including the screws) with a marking hole in the terminal block (available version without marking block). The back bar allows for perfect head stability and it allows for up/down and forward/backward adjustment thanks to an innovative articulation.

PROVIDED IN THE STANDARD VERSION

L'appui-tête articulé est unique dans sa conception, offrant une polyvalence et une précision extrêmes, les barres latérales sont amovibles et réglables (vers le haut/bas et gauche/droite) ainsi que rembourrées pour un confort maximal. Fabriquées en aluminium (y compris les vis) avec un point de repère au bout (version disponible sans point de repère). La barre arrière permet une parfaite stabilité de la tête ainsi que le réglage vers le haut/bas et avant/arrière grâce à un système d'articulation innovant.

FOURNI DANS LA VERSION STANDARD

Il design unico del poggiatesta articolato EDGE SURGICAL SOLUTIONS garantisce estrema versatilità e precisione, le barre laterali sono regolabili (su/giù e sinistra/destra) e rimovibili, imbottite per un miglior comfort e realizzate in alluminio (comprese le viti) con foro di marcatura nel blocco terminale (disponibile versione senza blocco di marcatura). La barra posteriore permette una perfetta stabilità della testa e permette la regolazione su/giù e avanti/indietro grazie a un'innovativa articolazione.

FORNITO NELLA VERSIONE STANDARD



codice

descrizione

9110666

ARTICULATED HEADREST WITH MARKING BLOCK



codice

descrizione

9110667

ARTICULATED HEADREST WITHOUT MARKING BLOCK

The side bars are equipped with a hole allowing the marking for the correct positioning of the Patient. Bars are also available without marker hole.

PROVIDED IN THE STANDARD VERSION

Les barres latérales sont équipées avec un trou de repère à l'extrémité permettant la marque du positionnement correct du Patient. Les barres sont également disponibles sans trou de repère.

FOURNI DANS LA VERSION STANDARD

Le barre laterali hanno il blocchetto terminale con il foro per il mark del posizionamento del Paziente. Le barre sono disponibili anche senza foro terminale.

FORNITO NELLA VERSIONE STANDARD





The side bars are adjustable (up/down and left/right) and removable, padded for better comfort and manufactured in Aluminium (including the screws). The back bar allows for perfect head stability and it allows for up/down and forward/backward adjustment thanks to an innovative articulation.

PROVIDED IN THE STANDARD VERSION

Les barres latérales sont amovibles et réglables (vers le haut/bas et gauche/droite) ainsi que rembourrées pour un confort maximal. Fabriquées en aluminium (y compris les vis). La barre arrière permet une parfaite stabilité de la tête ainsi que le réglage vers le haut/bas et avant/arrière grâce à un système d'articulation innovant.

FURNI DANS LA VERSION STANDARD

Le barre laterali sono regolabili (su/giù e sinistra/destra) e rimovibili, imbottite per un miglior comfort e realizzate in alluminio (comprese le viti). La barra posteriore permette una perfetta stabilità della testa e permette la regolazione su/giù e avanti/indietro grazie a un'innovativa articolazione.

FORNITO NELLA VERSIONE STANDARD

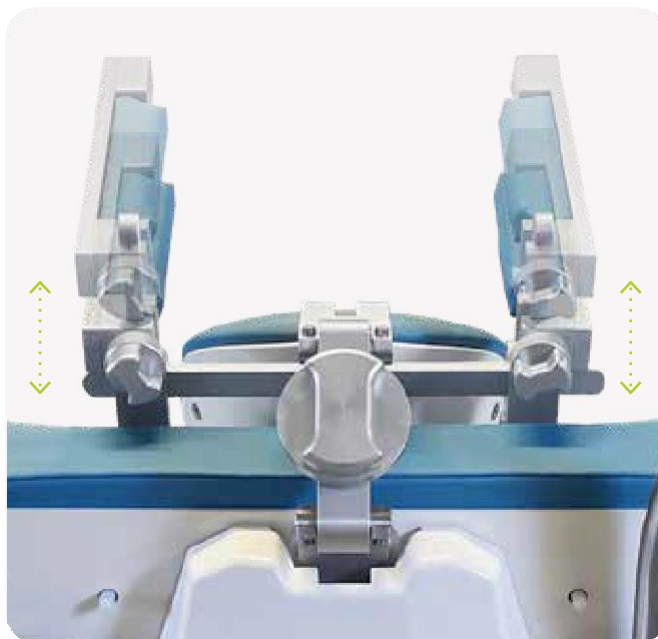

codice

descrizione

9110668

**COIL
SUPPORT**



The Coil support is equipped with an adjustable arm. The attachment is suitable with diameters between 28 and 34 mm. The support rod can be fixed both on the right side and on the left side.
OPTIONAL

Tige de support pour la bobine (COIL) équipée avec bras réglable. L'attache est compatible avec diamètres compris entre 28 et 34 mm. La tige de support peut être fixée aussi bien à droite qu' à gauche.
EN OPTION

Asta di supporto per coil con braccio regolabile. L'attacco per il coil è adatto per diametri tra i 28 e i 34 mm. L'asta di supporto può essere fissata sia a destra che a sinistra.
OPZIONALE



Arm-rest is shaped and padded according to the requirements of different medical sectors and can all be completely removed when necessary.

PROVIDED IN THE STANDARD VERSION

Les accoudoirs sont rembourrés et disponibles suivant les exigences des différents secteurs médicaux, et peuvent être complètement enlevés si nécessaire.

FURNI DANS LA VERSION STANDARD

I braccioli, interamente imbottiti e realizzati in forma ergonomica e idonei per le diverse discipline mediche, sono ribaltabili e completamente amovibili.

FORNITO NELLA VERSIONE STANDARD

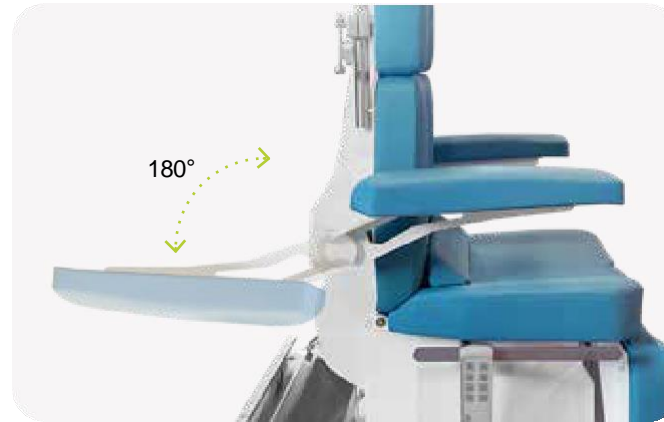

Both padded arm-rest are independently collapsible, removable and mechanically combined with the seat/back-rest movements ensuring comfort for the patient in any position.

Les deux accoudoirs rembourrés sont repliables de manière indépendante, amovibles et combinés mécaniquement avec les mouvements de l'assise et du dossier, garantissant le maximum de confort pour le patient dans toutes les positions.



Entrambi i braccioli imbottiti sono indipendentemente richiudibili, rimovibili e combinati meccanicamente con i movimenti del sedile e dello schienale assicurando comfort per il paziente in qualsiasi posizione.





Padded and shaped leg-rest.
PROVIDED IN THE STANDARD VERSION

Jambière rembourrée actionnée avec une commande au pied multifonction par actionneur linéaire.

FOURNI DANS LA VERSION STANDARD

Gambale imbottito e sagomato.
FORNITO NELLA VERSIONE STANDARD



Leg-rest operated with a multifunction foot control by with a linear actuator.

Jambière rembourrée actionnée avec une commande au pied multifonction par actionneur linéaire.

Il gambale è movimentato elettricamente da un attuatore lineare attivato dal pedale.



2 Stainless steel side rails mounted on the seat.
PROVIDED IN THE STANDARD VERSION

2 Rails latéraux en acier inoxydable montés sur l'assise.
FOURNI DANS LA VERSION STANDARD

2 barre laterali alla seduta in acciaio inox, idonee per accessori e applicazioni.
FORNITO NELLA VERSIONE STANDARD

EDGE^M TMS



The upholstery comprises 4 separate padded sections fully detachable for easy cleaning and disinfection, made of high density undeformable foam and the cover is a bi-elastic, abrasion-resistant, flame retardant and antimicrobial medical grade Skai available in over 80 different colours and textures.

PROVIDED IN THE STANDARD VERSION

La tapiserie comprend 4 sections rembourrées entièrement détachables pour faciliter le nettoyage et la désinfection. Réalisée en mousse indéformable de haute densité et une couverture enSkai de catégorie médicale, bi-élastique, résistant à l'abrasion, ignifuge et antimicrobienne. Disponible dans plus de 80 couleurs et textures différentes.

FOURNI DANS LA VERSION STANDARD

La tappezzeria comprende 4 sezioni imbottite completamente rimovibili per una facile pulizia e disinfezione, realizzate in schiuma indeformabile ad alta densità e con un rivestimento in Skai bi-elastico, resistente all'abrasione, ignifugo e antimicrobico, disponibile in oltre 80 diversi colori.

FORNITO NELLA VERSIONE STANDARD



EDGE^M TMS is provided in the standard version with the structure in White color or Silver at choice.

PROVIDED IN THE STANDARD VERSION

EDGE^M TMS est fourni dans la version standard avec la structure en couleur Blanc ou Argent à choix.

FOURNI DANS LA VERSION STANDARD

EDGE^M TMS è fornita nella versione standard con la struttura di colore Bianco o Silver a scelta.

FORNITO NELLA VERSIONE STANDARD



EDGE^M TMS

EDGE^MTMS is operated by a wireless foot control with modern design and extremely intuitive. Easy to operate and clean, the foot control provides the Professional with an ergonomic and efficient working tool, useful to position the Patient comfortably and memorize different working or safety positions.

The foot control has 8 buttons to operate the 4 actuator and move the Chair sections; it is also provided with 2 memorizable positions buttons (M1,M2), the easy Patient Access-Exit position (M0), and the Sync button that enables leg-rest and back-rest simultaneous movement.

The foot control is also equipped with two buttons for the emergency positions of the Chair: the flat position and the Trendelenburg position. The pedal innovative visual and acoustic signals communicate all safety, memorized movements and charging activity of the chair and it's foot control.

OPTIONAL



Foot control support for back rail.

OPTIONAL

Support de la pédale sur rail en arrière du Fauteuil.

EN OPTION

Supporto pedale per rail posteriore.

OPZIONALE

EDGE^MTMS est équipé d'une commande au pied sans fil avec un design moderne, aux fonctions simples et intuitives. Facile à utiliser et à désinfecter, la pédale garantit au Professionnel un outil de travail ergonomique et efficace, idéal pour positionner confortablement le patient et mémoriser différentes positions de travail ou de sécurité.

La pédale a 8 touches activant les 4 moteurs permettant le mouvement des différentes sections du fauteuil; La commande au pied est équipée de 2 touches de position mémorisées (M1, M2), de la touche mémoire "0" pour un accès et une sortie aisés du patient, et de la touche Sync qui active le mouvement simultané et synchronisé du dossier et de la jambière.

La pédale est également équipée de deux touches pour les positions d'urgence du Fauteuil: position table d'examen et position Trendelenburg.

Les signaux acoustiques / visuels innovants de la pédale communiquent les mouvements mémorisés, les dispositifs de sécurité, le rechargement de la batterie et toutes les activités du fauteuil.

EN OPTION

EDGE^MTMS ha in dotazione un pedale wireless dal design moderno, semplice e intuitivo nelle sue funzioni. Facile da utilizzare e igienizzare, il pedale garantisce al Professionista uno strumento di lavoro ergonomico ed efficiente, utile ed immediato nel posizionare comodamente il Paziente ed in grado di memorizzare diverse posizioni di lavoro o sicurezza.

Il pedale ha 8 tasti che attivano i 4 attuatori permettendo il movimento delle diverse sezioni della Poltrona; è dotato di 2 tasti di posizione memorizzabili (M1,M2), il tasto di memoria "0" per l'accesso e l'uscita agevole del Paziente, e il tasto Sync che attiva il movimento simultaneo e sincronizzato dello schienale e del gambale.

Il pedale è dotato, inoltre, di due tasti per il richiamo delle posizioni di emergenza: la posizione a lettino e la posizione Trendelenburg.

Le innovative segnalazioni acustiche/visive del pedale comunicano movimenti memorizzati, sicurezze, ricarica della batteria e attività della Poltrona in movimento.

OPZIONALE

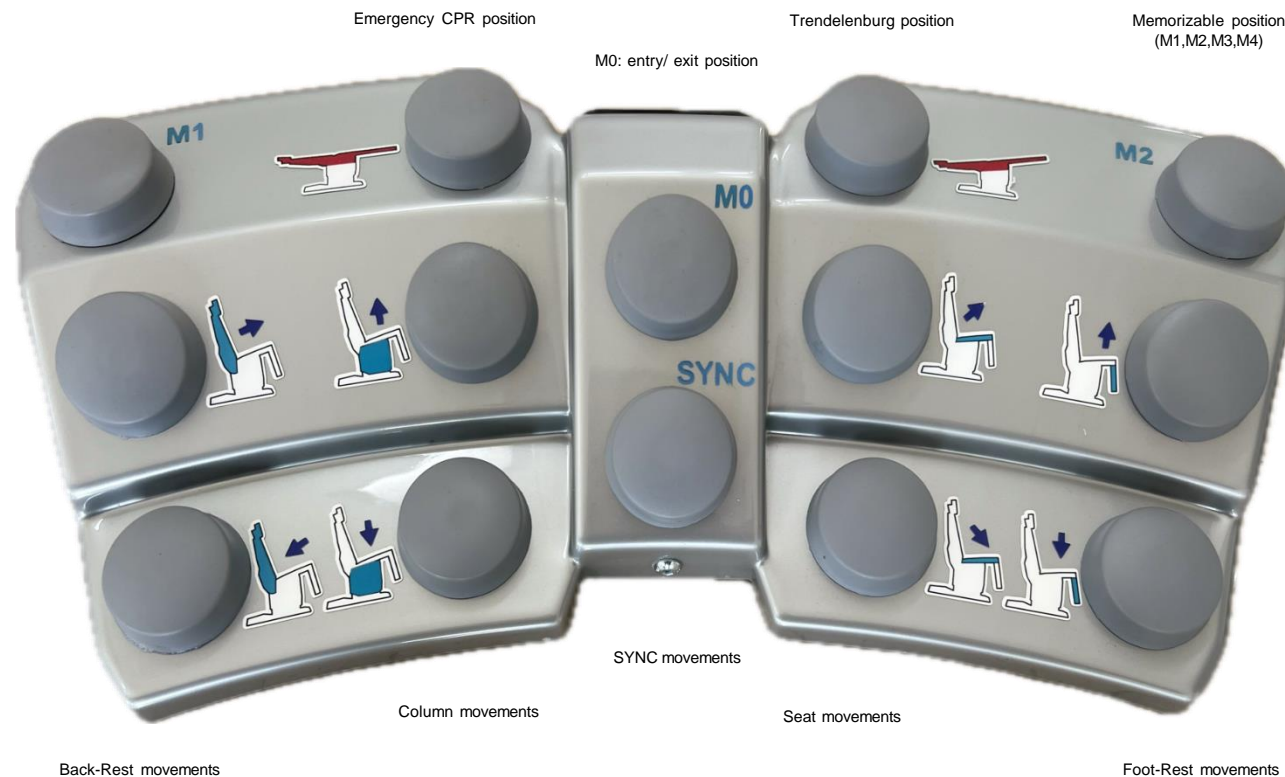



codice	descrizione
9110630	HAND CONTROL

The Hand Control enables the required positioning of the Patient, by activating the linear actuators that control the position of each independent section (lifting column, seat, back-rest and foot-rest).

PROVIDED IN THE STANDARD VERSION

Le clavier de commande manuelle permet le positionnement souhaité du Patient, en activant les actionneurs linéaires qui contrôlent le mouvement de chaque section indépendante (colonne télescopique, assise, dossier et jambière).

FOURNI DANS LA VERSION STANDARD

La Tastiera permette di selezionare le posizioni di lavoro richieste, attivando la movimentazione degli attuatori elettrici che regolano il posizionamento delle sezioni indipendenti (sollevamento, seduta, schienale e gambale).

FORNITO NELLA VERSIONE STANDARD



codice	descrizione
9110610	HALF ROUND BOLSTER PILLOW

Half Round Bolster Pillow.
OPTIONAL
Cousin de support semi-circulaire.
EN OPTION
Cuscino di Supporto semi-circolare.
OPZIONALE



codice	descrizione
9110611	FULL ROUND BOLSTER PILLOW

Full Round Bolster Pillow.
OPTIONAL
Cousin de support circulaire.
EN OPTION
Cuscino di Supporto circolare.
OPZIONALE



codice	descrizione
9110621	LUMBAR SUPPORT PILLOW

codice	descrizione
9110632	BODY VELCRO TAPE



Body Velcro tape for Patient stabilization and containment.

OPTIONAL

Bande en Velcro pour stabiliser et contenir le Patient
EN OPTION

Nastro Velcro per la stabilizzazione e il contenimento del Paziente.
OPZIONALE

codice	descrizione
9110645	BODY TAPE WITH BUCKLE



Belt with buckle for stabilization and containment of the Patient.

OPTIONAL

Ceinture avec boucle pour la stabilisation et le confinement du Patient.
EN OPTION

Nastro con fibbia per la stabilizzazione e il contenimento del Paziente.
OPZIONALE

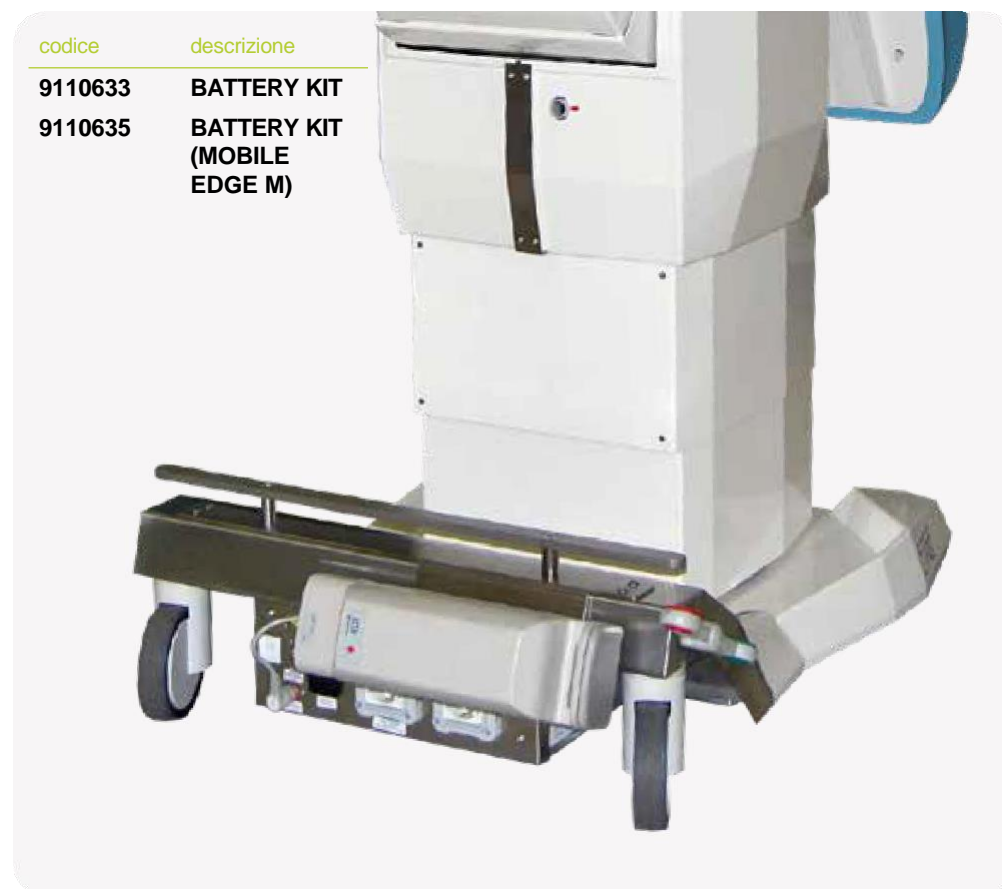

Battery kit including two batteries (capacity 5Ah), with capacity indicator and recharger, allowing to operate the Chair without electrical supply connection. Replacing the battery with the spare one provided is very simple.

OPTIONAL

Kit de batterie comprenant deux batteries (capacité 5Ah), avec indicateur de capacité et rechargeur, permettant de gérer le Fauteuil sans connexion électrique. Le remplacement de la batterie par celle de rechange fournie est très simple.

EN OPTION

Kit batterie costituito da coppia di batterie (capacità 5Ah), con indicatore di capacità, e con carica batterie. Consente di operare con la Poltrona senza collegamento alla rete elettrica. Facilità di sostituzione della batteria con quella di scorta.

OPZIONALE

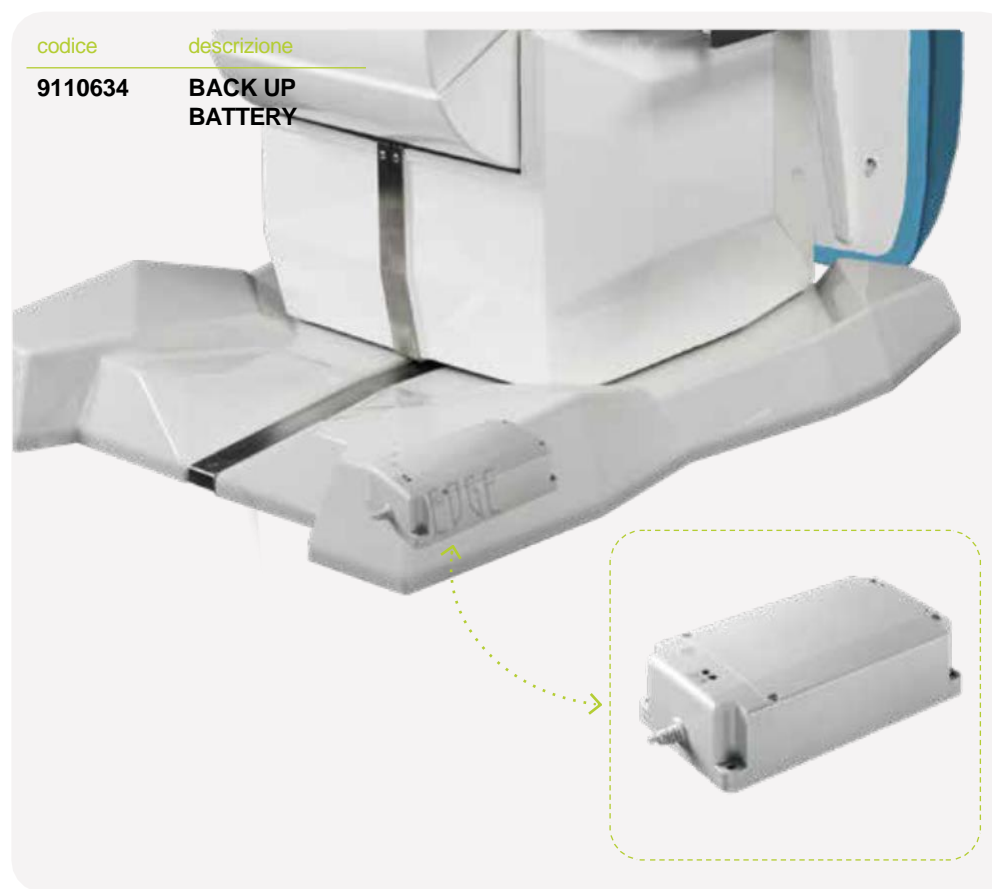

Back up battery with 2Ah capacity allowing to operate the Chair in the event of a temporary power outage.

OPTIONAL

Batterie avec système back up et capacité de 2Ah permettant de gérer le Fauteuil en cas de coupure de courant temporaire.

EN OPTION

Batteria back up con capacità di 2Ah. Consente di movimentare la Poltrona in caso di interruzione momentanea della corrente elettrica.

OPZIONALE



codice	descrizione
9110651	FOOT CONTROL SUPPORT

Foot control support for back rail.
OPTIONAL ON MOBILE EDGE M TMS

Support de la pédale sur rail en arrière du Fauteuil.
EN OPTION SUR EDGE M TMS SUR ROUES

Supporto pedale per rail posteriore.
OPZIONALE SU EDGE M TMS SU RUOTE



codice	descrizione
9110631	RACK FOR MEDICAL ACCESSORIES (white structure)
9110631S	RACK FOR MEDICAL ACCESSORIES (silver structure)

Edge accessories rack inox.
OPTIONAL

Grille porte- accessoires Edge en inox.
EN OPTION

Carrello porta- accessori Edge in inox.
OPZIONALE

DIMENSIONS AND TECHNICAL SHEETS
DIMENSIONS ET FICHES TECHNIQUES
DIMENSIONI E DATI TECNICI

EDGE M TMS

Transcranial Magnetic
Stimulation Chair

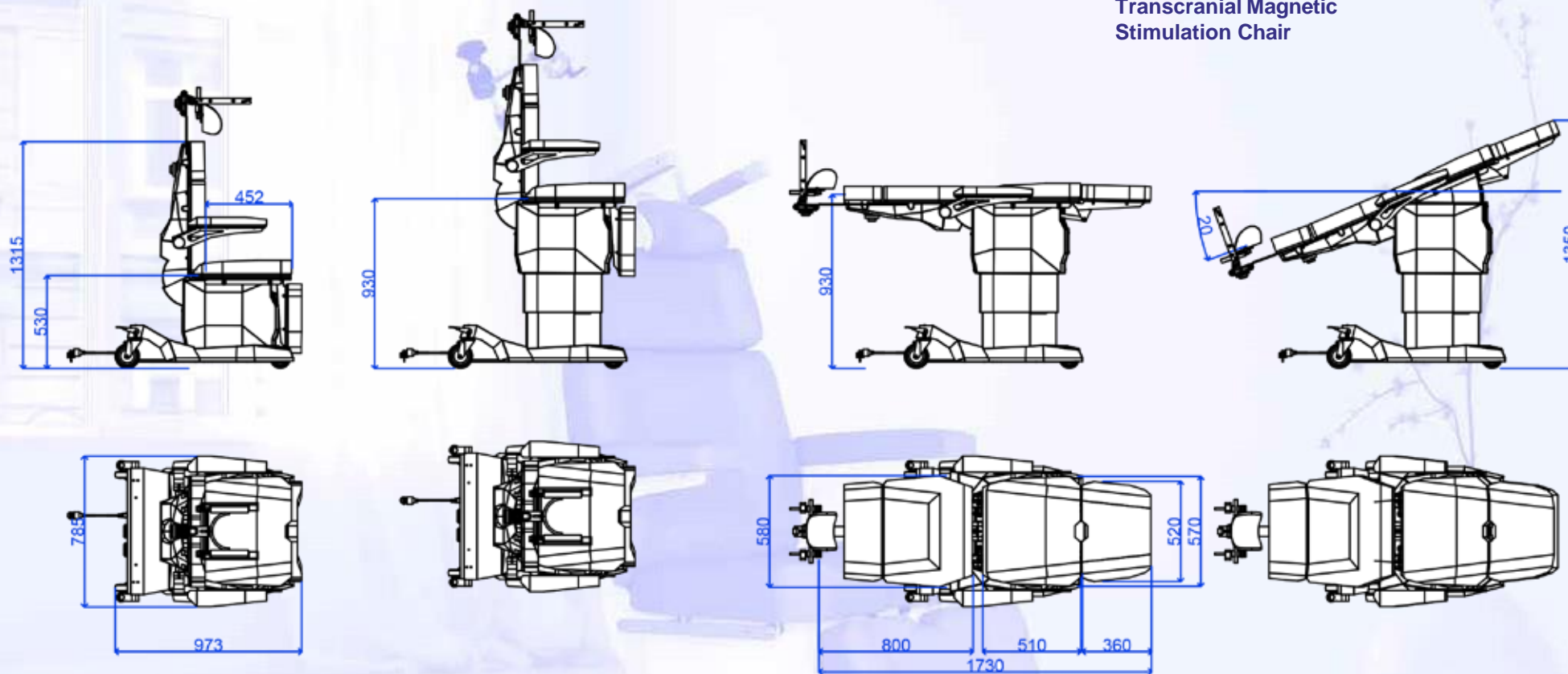

Supply <i>Alimentation</i> Alimentazione	110- 230 V 50- 60 Hz
Operating voltage <i>Voltage</i> Tensione di rete	24 V
Absorption <i>Absorption</i> Assorbimento	350 W
Maximum load <i>Capacité maximum</i> Capacità di carico	325 Kg

Maximum load on foot-rest <i>Capacité maximum sur jambière</i> Capacità di carico sul gambale	85 Kg
Maximum load on arm-rest <i>Capacité maximum sur accoudoir</i> Capacità di carico sul bracciolo	75 Kg
Maximum load on back-rest <i>Capacité maximum sur dossier</i> Capacità di carico sullo schienale	75 Kg
Weight of the chair <i>Poids du fauteuil</i> Peso della poltrona	140 Kg

DIMENSIONS AND TECHNICAL SHEETS
DIMENSIONS ET FICHES TECHNIQUES
DIMENSIONI E DATI TECNICI

EDGEM TMS

Transcranial Magnetic Stimulation Chair

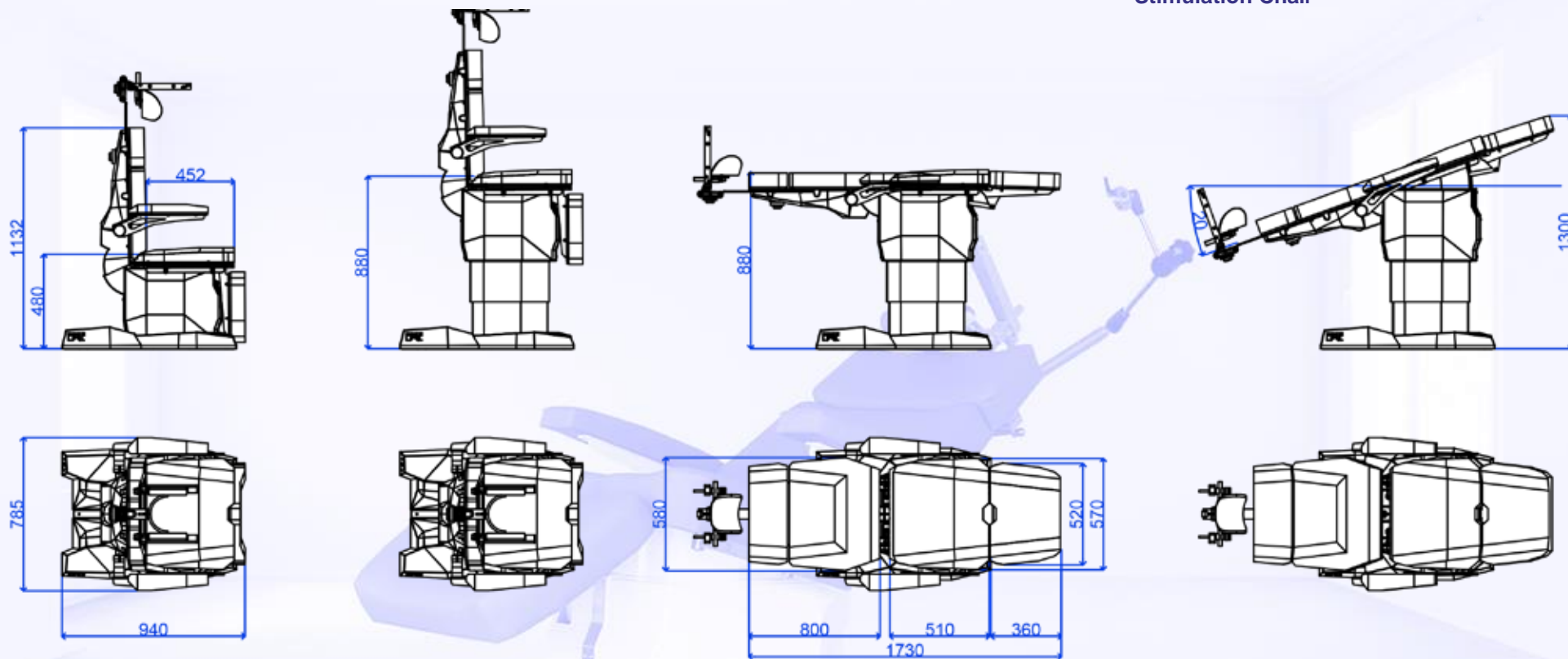

Supply <i>Alimentation</i> Alimentazione	110- 230 V 50- 60 Hz
Operating voltage <i>Voltage</i> Tensione di rete	24 V
Absorption <i>Absorption</i> Assorbimento	350 W
Maximum load <i>Capacité maximum</i> Capacità di carico	325 Kg

Maximum load on foot-rest <i>Capacité maximum sur jambière</i> Capacità di carico sul gambale	85 Kg
Maximum load on arm-rest <i>Capacité maximum sur accoudoir</i> Capacità di carico sul bracciolo	75 Kg
Maximum load on back-rest <i>Capacité maximum sur dossier</i> Capacità di carico sullo schienale	75 Kg
Weight of the chair <i>Poids du fauteuil</i> Peso della poltrona	140 Kg



80 colours available

codice	descrizione
9120133	HP GEL WITHOUT FOOT REST
9120134	HP GEL WITH FOOT REST
9120136	HP GEL WITHOUT FOOT REST - HIGH
9120137	HP GEL WITH FOOT REST - HIGH

The seat naturally adapts to the user's body by increasing the contact area and decreasing the pressure on it. Circular seat with visco-elastic foam in different densities and memory effect. Multifunction armrest/back rest in high resistant polyurethane. Base in steel and polished chrome. 5 self braking wheels. Adjustable height by gas piston. High quality skay cover.

OPTIONAL

Siège opérateur avec assise circulaire en mousse viscoélastique de différentes densités, avec effet mémoire. Accoudoir/ dossier multifonctionnel en polyuréthane de haute résistance. Appui-pied en acier chromé réglable en hauteur par vérin à gaz. Revêtement en skai de haute qualité.

EN OPTION

Sedia operatore con seduta circolare in schiuma viscoelastica a densità differenziata, con effetto memoria. Bracciolo/ schienale multifunzionale in poliuretano ad alta resistenza. Base in acciaio cromato. Altezza regolabile tramite molla a gas. Rivestimento con skai di alta qualità

OPZIONALE

80 colours available

codice	descrizione
9120430	HL GEL WITHOUT FOOT REST
9120431	HL GEL WITH FOOT REST
9120432	HL GEL WITHOUT FOOT REST - HIGH
9120433	HL GEL WITH FOOT REST - HIGH

Doctor stool with anatomical seat. Adjustable height of the backrest. Inclination angle of the backrest is adjustable in a fixed position or can dynamically support the back muscles. Control lever for all adjustments. Base in chromed steel. Seat height adjustable by gas spring. High quality skay coating.

OPTIONAL

Siège opérateur avec assise anatomique. Hauteur du dossier réglable. L'angle d'inclinaison du dossier est réglable dans une position fixe ou peut soutenir dynamiquement les muscles du dos. Réglages par levier. Base en acier chromé. Hauteur de l'assise réglable par vérin à gaz. Revêtement en skay de haute qualité.

EN OPTION

Sedia operatore con seduta anatomica. Altezza dello schienale regolabile. L'angolo di inclinazione dello schienale è regolabile in una posizione fissa o può supportare dinamicamente i muscoli della schiena. Leva di comando per tutte le regolazioni. Base in acciaio cromato. Altezza del sedile regolabile tramite molla a gas. Rivestimento in skay di alta qualità

OPZIONALE

UPHOLSTERY - SELLERIE - TAPPEZZERIA

EDGE SURGICAL SOLUTIONS Cool

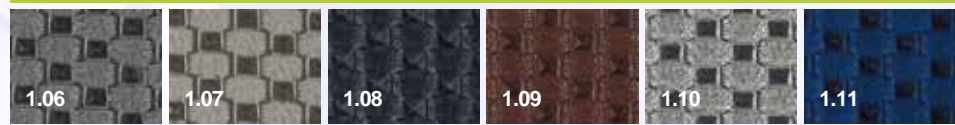

BTC Urban

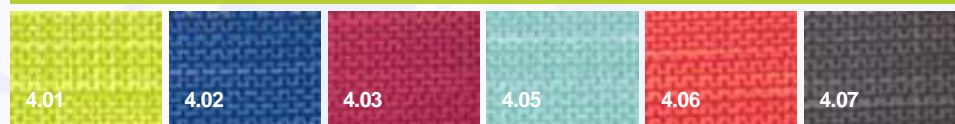

EDGE SURGICAL SOLUTIONS Brio

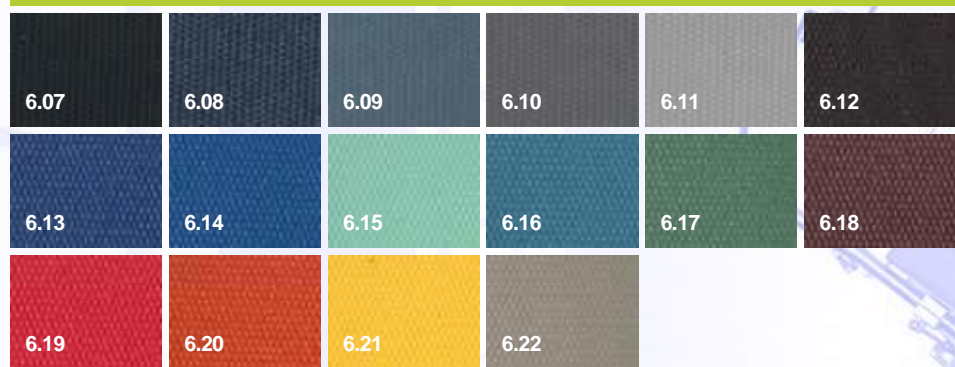

EDGE SURGICAL SOLUTIONS Voyager

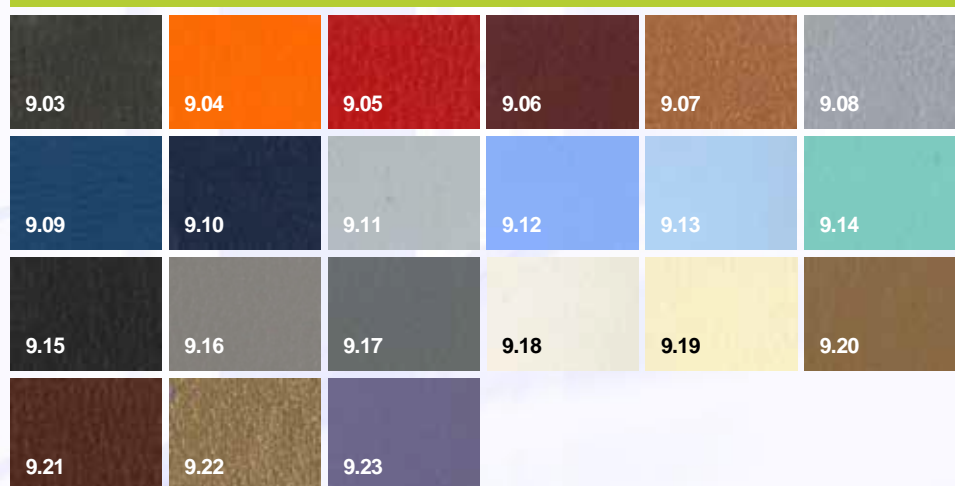

EDGE SURGICAL SOLUTIONS Glamour

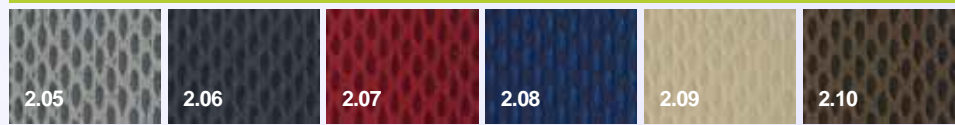

EDGE SURGICAL SOLUTIONS Trend

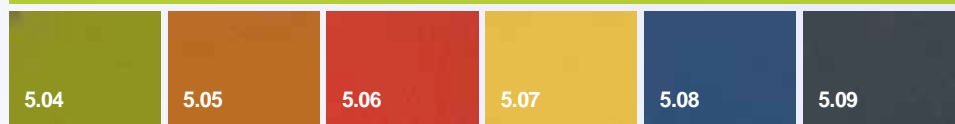

EDGE SURGICAL SOLUTIONS Premium

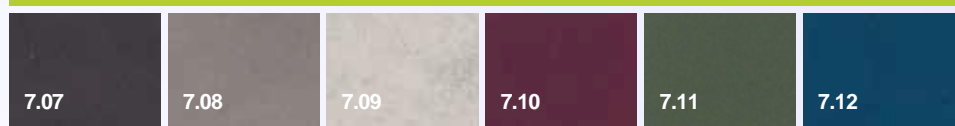

EDGE SURGICAL SOLUTIONS Classic

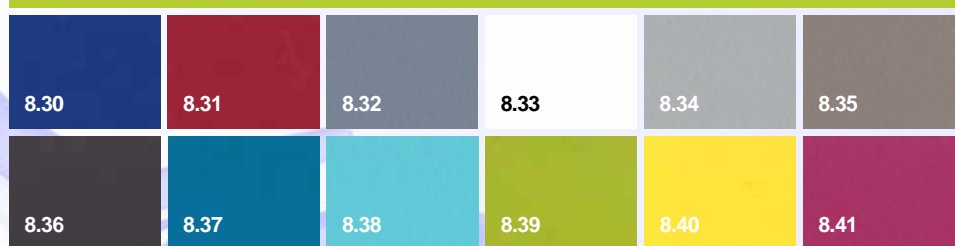

EDGE SURGICAL SOLUTIONS Antistatic

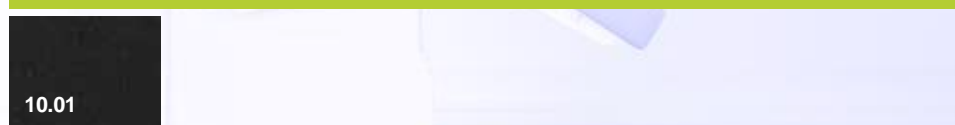

UPHOLSTERY - SELLERIE - TAPPEZZERIA

EDGE SURGICAL SOLUTIONS Cool

- Fireproof**
EN 1021.1-2
IMO MSC 88/26/ADD.2 PART 8
(3.1&3.2), ISO 3795
- Bleach resistant**
- REACH Compliant**
Non toxic
Non heavy metals
No mercury
- No Bisphenol A (BPA)**
- RoHS Compliant**
- No PBTs (Persistent Bio accumulative and Toxic Chemicals)**
- No significant colour change or stiffening**
UV coef ≥ 7
- Bromine-free, no Halogenated Flame Retardants (HFRs)**
- Phtalates free**
- Abrasion resistant**
100.000 cycles
- Mildew resistant**

EDGE SURGICAL SOLUTIONS Trend

- Fireproof**
EN 1021.1-2
IMO MSC 88/26/ADD.2 PART 8
(3.1&3.2)
- Bleach resistant**
- REACH Compliant**
Non toxic
Non heavy metals
No mercury
- No Bisphenol A (BPA)**
- RoHS Compliant**
- No PBTs (Persistent Bio accumulative and Toxic Chemicals)**
- No significant colour change or stiffening**
UV coef ≥ 7
- Bromine-free, no Halogenated Flame Retardants (HFRs)**
- Phtalates free**
- Abrasion resistant**
100.000 cycles
- Fire resistant additives free**
Antimicrobial resistant additive free
Phtalates free

EDGE SURGICAL SOLUTIONS Classic

- Fireproof**
M1 (NFP 92503)
BS 5852 crib 5
B2 (DIN 4102)
EN 1021.1-2
IMO A652
FAR 25853 App F Part1 v12
CATB 117 E
CATB 133
UFAC CLASS 1
NY/NJ-Port Authority
AM 18 (NFD 60-013)
- Waterproof**
- Efficacy against bacteria (MRSA)**
- Abrasion resistant**
ISO 5470-2
150.000 cycles (12 KPa)
- Colour fastness to artificial light**
 ≥ 6
- Phtalates free**

EDGE SURGICAL SOLUTIONS Glamour

- Fireproof**
EN 1021.1-2
IMO MSC 88/26/ADD.2 PART 8
(3.1&3.2), ISO 3795
- Bleach resistant**
- REACH Compliant**
Non toxic
Non heavy metals
No mercury
- No Bisphenol A (BPA)**
- RoHS Compliant**
- No PBTs (Persistent Bio accumulative and Toxic Chemicals)**
- No significant colour change or stiffening**
UV coef ≥ 7
- Bromine-free, no Halogenated Flame Retardants (HFRs)**
- Phtalates free**
- Abrasion resistant**
100.000 cycles
- Mildew resistant**

EDGE SURGICAL SOLUTIONS Brio

- Fireproof**
BS EN 1021-1 and 2
NF P 92-503 (M2)
IMO MSC 88/26/ADD.2 PART 8
(3.1&3.2)
CATB 117-2013
UFAC CLASS 1
- Bleach resistant**
- REACH Compliant**
Non toxic
Non heavy metals
No mercury
- No Bisphenol A (BPA)**
- RoHS Compliant**
- No PBTs (Persistent Bio accumulative and Toxic Chemicals)**
- No significant colour change or stiffening**
UV coef ≥ 7
- Bromine-free, no Halogenated Flame Retardants (HFRs)**
- Phtalates free**
- Abrasion resistant**
300.000 cycles
- Anti-microbial**
Mildew resistant

EDGE SURGICAL SOLUTIONS Voyager

- Fireproof**
CL 1/ IM-M2-CRIB 5
- Waterproof**
- UV resistant, low temp. resistant**
- Efficacy against bacteria, antibacterial and antimicrobial**
- Free of heavy metal, formaldehyde, mercury and solvents**
- Abrasion resistant**
ISO 5470-2
100.000 cycles
- Chemical resistant to acid, bases, alcohol and common solvent**

EDGE SURGICAL SOLUTIONS Urban

- Fireproof**
M2 (NFP 92503)
BS 5852 crib 5
B2 (DIN 4102)
EN 1021.1-2
IMO A652
FAR 25853 App F Part1 v12
CATB 117 E
CATB 133
UFAC CLASS 1
NY/NJ-Port Authority
AM 18 (NFD 60-013)
- Waterproof**
- Efficacy against bacteria (MRSA)**
- Abrasion resistant**
ISO 5470-2
120.000 cycles (12 KPa)
- Colour fastness to artificial light**
 ≥ 6
- Phtalates free**

EDGE SURGICAL SOLUTIONS Premium

- Fireproof**
M2 (NFP 92503)
BS 5852 crib 5
B2 (DIN 4102)
EN 1021.1-2
IMO A652
FAR 25853 App F Part1 v12
CATB 117 E
CATB 133
UFAC CLASS 1
NY/NJ-Port Authority
AM 18 (NFD 60-013)
- Waterproof**
- Efficacy against bacteria (MRSA)**
- Abrasion resistant**
ISO 5470-2
80.000 cycles (12 KPa)
- Colour fastness to artificial light**
 ≥ 6
- Phtalates free**

EDGE SURGICAL SOLUTIONS Antistatic

- Electrically conductive (antistatic) synthetic leather**
- Fireproof**
GOST
- REACH Compliant**
- No significant colour change or stiffening**
 ≥ 6
- Electric Resistivity**
 $10^4-10^6 \Omega$
- Phtalates free**

A series of horizontal dotted lines for writing notes.



www.edgesurgicalsolutions.com



edgesurgicalsolutions@gmail.com

CE



*“All EDGE SURGICAL SOLUTIONS Medical Equipment is designed ,
developed and manufactured in Italy”*

EDGE SURGICAL SOLUTIONS Srl

Headquarter: Via Umberto I, 48 73039 Tricase (LE) –ITALY

Production Site: S.S.275 Alessano-Lucugnano KM 17,5
73031 ALESSANO (LE) - ITALY